

15116
Pyroxene Basalt
7.2 grams



Figure 1: Photo of rake sample 15116. Scale in cm. S71-48754.

Mineralogical Mode

Olivine	
Pyroxene	60
Plagioclase	30
Opagues	5
Silica	4
Meostasis	1
Dowty et al. 1973	

Introduction

15116 was collected as part of a rake sample from station 2, Apollo 15 (Swann et al. 1972). It is a coarse-grained pyroxene-rich mare basalt. It has not been dated.

Petrography

Dowty et al. (1973) described the texture of 15116 as “gabbroic” (figure 2 a,b). However the pyroxene crystals are complexly zoned, as is typical of basalt. There is no olivine and there is excess silica.

Mineralogy

Olivine: none

Pyroxene: Dowty et al. (1974) studied the complex zoning in pyroxenes (figure 3).

Spinel: Nehru et al. (1974) found that there was a distinct transition from chromite cores to ulvospinel overgrowth in the spinel grains.

Silica: Tridymite occurs as large parallel intergrowths in the outer margins of pyroxene and plagioclase grains. Cristobalite is also present in the interstices.

Chemistry

Helmke et al. (1973) determined the chemical composition (figure 4).

Radiogenic age dating

Not dated

Processing

There are 5 thin sections of 15116.

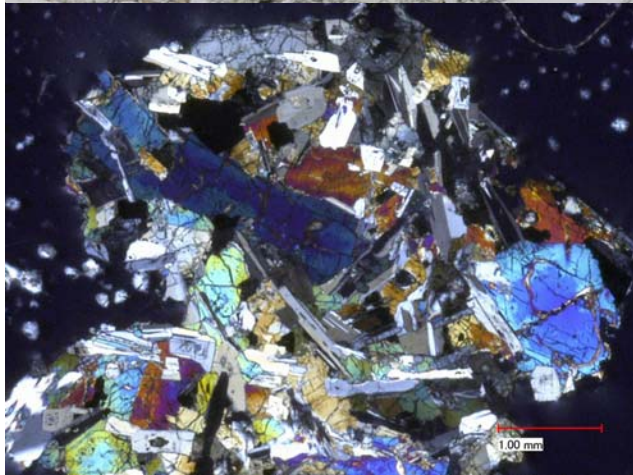
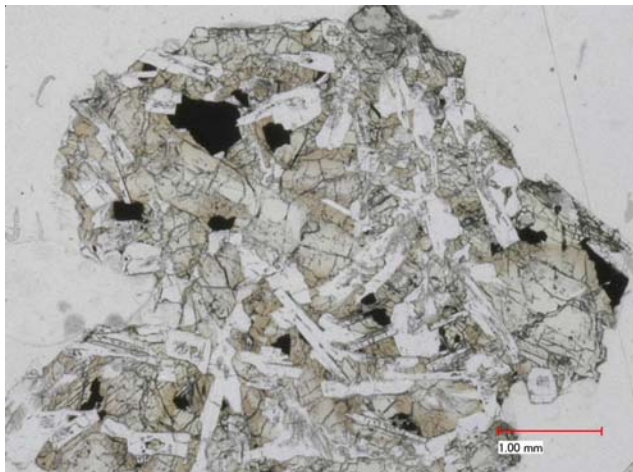

Figure 2: Photomicrographs of thin section 15116,10 by C Meyer @50x.

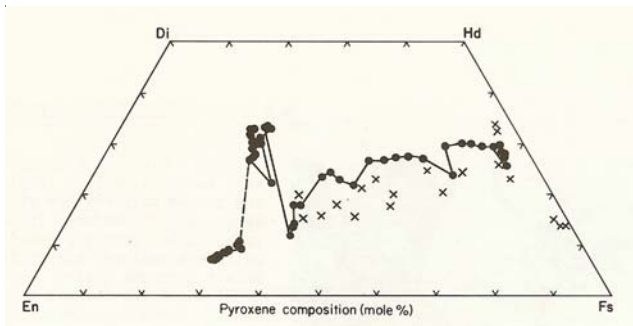

Figure 3: Pyroxene composition of 15116 (Dowty et al. 1973).

Lunar Basalts

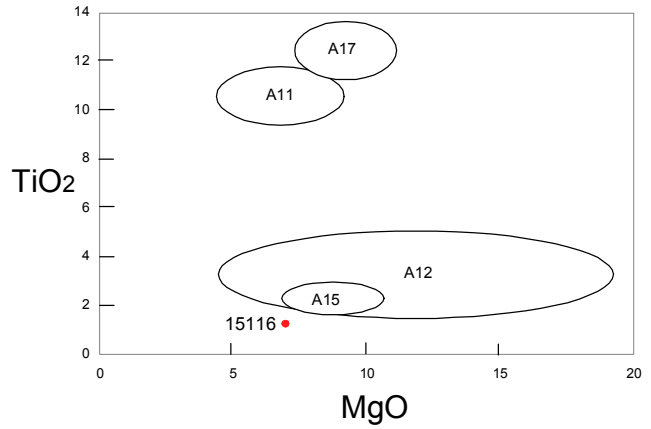

Figure 4: Chemical composition of 15116 compared with that of other Apollo basalts.

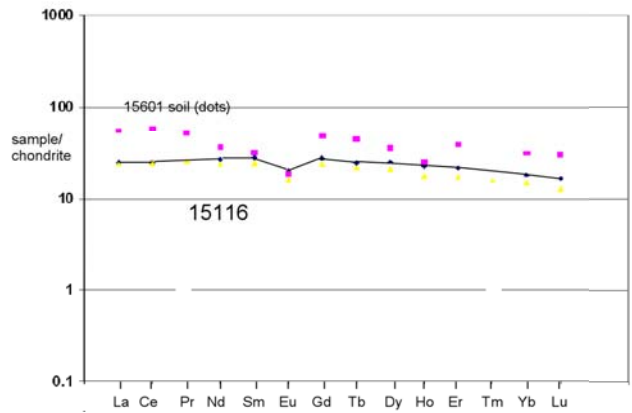

Figure 5: Normalized rare-earth-element diagram for 15116 with soil 15601 for comparison.

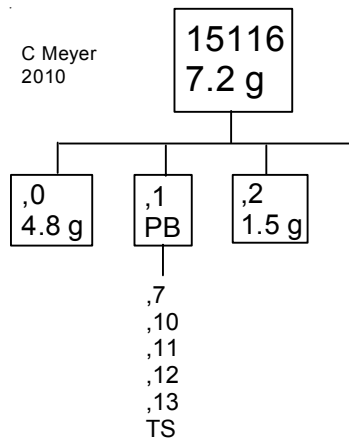

Table 1. Chemical composition of 15116.

reference weight	Dowty73	Helmke73	
SiO ₂ %	49.2	(b) 51	(c)
TiO ₂	1.16	(b) 1.78	(c)
Al ₂ O ₃	10.2	(b) 9.94	(c)
FeO	19	(b) 20	(c)
MnO	0.22	(b) 0.26	(a)
MgO	7.3	(b) 7.87	(c)
CaO	10.4	(b) 9.57	(c)
Na ₂ O	0.38	(b) 0.335	(c)
K ₂ O	0.02	(b) 0.06	(c)
P ₂ O ₅	0.04	(b)	
S %			
sum			
Sc ppm		50.8	(a)
V			
Cr		2650	(a)
Co		35	(a)
Ni			
Cu			
Zn		2.7	(a)
Ga		4.1	(a)
Ge ppb			
As			
Se			
Rb		1	(a)
Sr			
Y			
Zr			
Nb			
Mo			
Ru			
Rh			
Pd ppb			
Ag ppb			
Cd ppb			
In ppb			
Sn ppb			
Sb ppb			
Te ppb			
Cs ppm		0.051	(a)
Ba			
La		5.73	(a)
Ce		14.8	(a)
Pr			
Nd		12	(a)
Sm		4.05	(a)
Eu		1.1	(a)
Gd		5.3	(a)
Tb		0.88	(a)
Dy		6.02	(a)
Ho		1.23	(a)
Er		3.4	(a)
Tm			
Yb		2.9	(a)
Lu		0.396	(a)
Hf		2.4	(a)
Ta			
W ppb			
Re ppb			
Os ppb			
Ir ppb			
Pt ppb			
Au ppb			
Th ppm			
U ppm			

technique: (a) INAA, (b) broad beam e-probe, (c) AA

References for 15116

Butler P. (1971) Lunar Sample Catalog, Apollo 15. Curators' Office, MSC 03209

Dowty E., Prinz M. and Keil K. (1973b) Composition, mineralogy, and petrology of 28 mare basalts from Apollo 15 rake samples. *Proc. 4th Lunar Sci. Conf.* 423-444.

Dowty E., Keil K. and Prinz M. (1974c) Lunar pyroxene-phyric basalts: Crystallization under supercooled conditions. *J. Petrology* **15**, 419-453.

Dowty E., Conrad G.H., Green J.A., Hlava P.F., Keil K., Moore R.B., Nehru C.E. and Prinz M. (1973a) Catalog of Apollo 15 rake samples from stations 2 (St. George), 7 (Spur Crater) and 9a (Hadley Rille). *Inst. Meteoritics Spec. Publ.* No 11, 51-73. Univ. New Mex. ABQ.

Helmke P.A., Blanchard D.P., Haskin L.A., Telander K., Weiss C. and Jacobs J.W. (1973) Major and trace elements in igneous rocks from Apollo 15. *The Moon* **8**, 129-148.

Lofgren G.E., Donaldson C.H. and Usselman T.M. (1975) Geology, petrology and crystallization of Apollo 15 quartz-normative basalts. *Proc. 6th Lunar Sci. Conf.* 79-99.

LSPET (1972a) The Apollo 15 lunar samples: A preliminary description. *Science* **175**, 363-375.

LSPET (1972b) Preliminary examination of lunar samples. Apollo 15 Preliminary Science Report. NASA SP-289, 6-1—6-28.

Nehru C.E., Prinz M., Dowty E. and Keil K. (1974) Spinel-group minerals and ilmenite in Apollo 15 rake samples. *Am. Mineral.* **59**, 1220-1235.

Ryder G. (1985) Catalog of Apollo 15 Rocks (three volumes). Curatorial Branch Pub. # 72, JSC#20787

Swann G.A., Hait M.H., Schaber G.C., Freeman V.L., Ulrich G.E., Wolfe E.W., Reed V.S. and Sutton R.L. (1971b) Preliminary description of Apollo 15 sample environments. U.S.G.S. Interagency report: 36. pp219 with maps

Swann G.A., Bailey N.G., Batson R.M., Freeman V.L., Hait M.H., Head J.W., Holt H.E., Howard K.A., Irwin J.B., Larson K.B., Muehlberger W.R., Reed V.S., Rennilson J.J., Schaber G.G., Scott D.R., Silver L.T., Sutton R.L., Ulrich G.E., Wilshire H.G. and Wolfe E.W. (1972) 5. Preliminary Geologic Investigation of the Apollo 15 landing site. In Apollo 15 Preliminary Science Rpt. NASA SP-289. pages 5-1-112.