

12065
Pigeonite Basalt
2109 grams



Figure 1: Photo of 12065 showing numerous zap pits on rounded surface. Scale is in cm. NASA # S69-60591.

Introduction

Sample 12065 is a large rounded pigeonite basalt dated at 3.16 ± 0.09 b.y. The outer surface is covered with micrometeorite pits on all sides (figure 1).

Petrography

12065 is a variolitic basalt composed of pyroxene and olivine phenocrysts (figure 2) imbedded in a very fine matrix of feathery ilmenite, plagioclase and clinopyroxene (figure 3)(Reid 1971). Kushiro et al. (1971) find that the fibrous pyroxene in 12065 is similar to “quench pyroxenes” often found in quenching experiments. 12065 has a few percent void space.

Kushiro et al. (1971) used the bulk composition of 12065 to perform experiments leading to the conclusion

that near-surface olivine (Fo_{74}) and some pyroxene settling could explain the variation in composition of some Apollo 12 basalts.

Mineralogy

Olivine: Olivine composition in 12065 ranges from Fo_{72-32} (Kushiro et al. 1971).

Pyroxene: Hollister et al. (1971) and Kushiro et al. (1971) describe complex sector zoning of pyroxene phenocrysts in 12065 (figure 4). Pigeonite cores are overgrown by subcalcic augite (Gay et al. 1971). Kushiro et al. report extreme Fe-enrichment in matrix pyroxene. Gay et al. report pyroxferroite with low Ca.

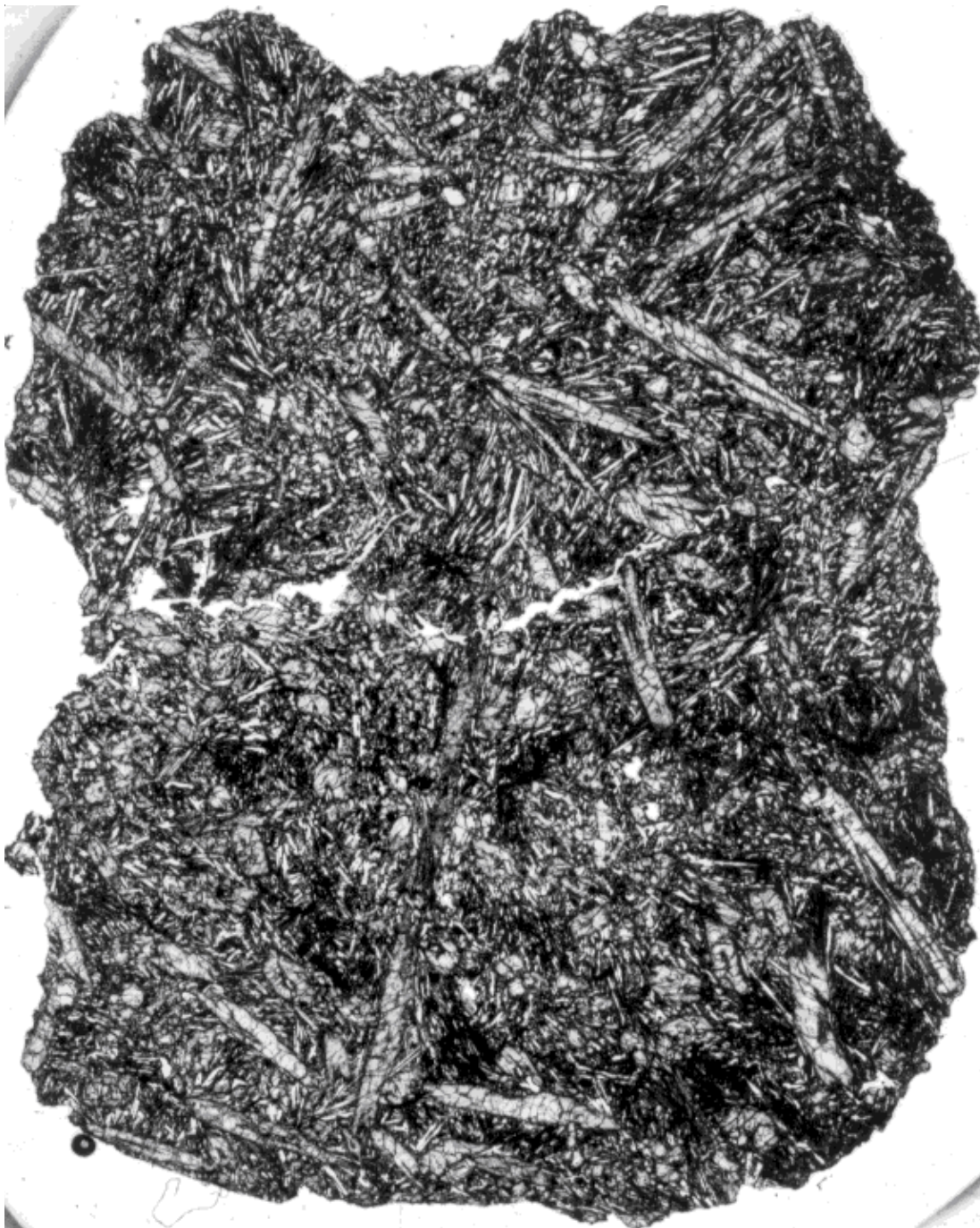

Figure 2: Photomicrograph of thin section 12065 showing elongate pyroxene in variolitic groundmass. Scale is about 2 cm. NASA # S69-23378.

Plagioclase: Plagioclase is $An_{91} - An_{89}$ (Kushiro et al. 1971).

Spinel: The Ti content of the Cr-spinel increases with iron content from center to edge (Reid 1971). Kushiro et al. (1971) reported a large compositional gap between ulvöspinel and chromite.

Chemistry

The chemical composition of 12065 has been reported by LSPET (1970), Maxwell et al. 1971, Kushiro et al. (1971), Goles et al. (1971), Smales et al. (1971), Bouchet et al. (1971) and Wänke et al. (1971) (table 1, figures 5 and 6). Moore et al. (1971) determined 31

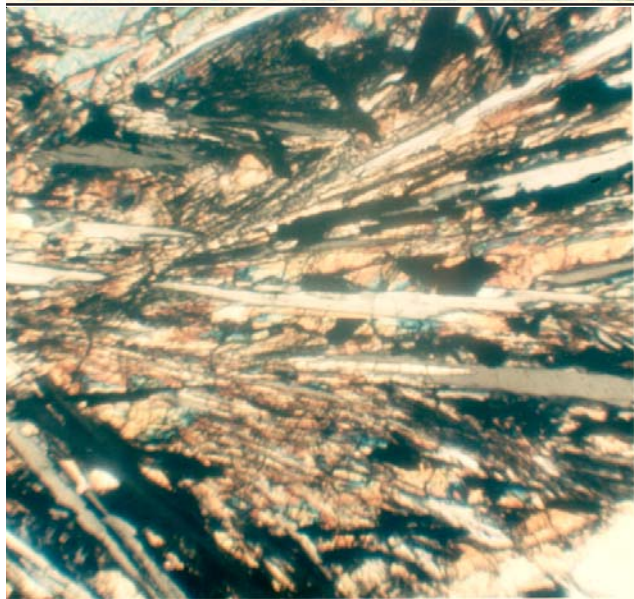
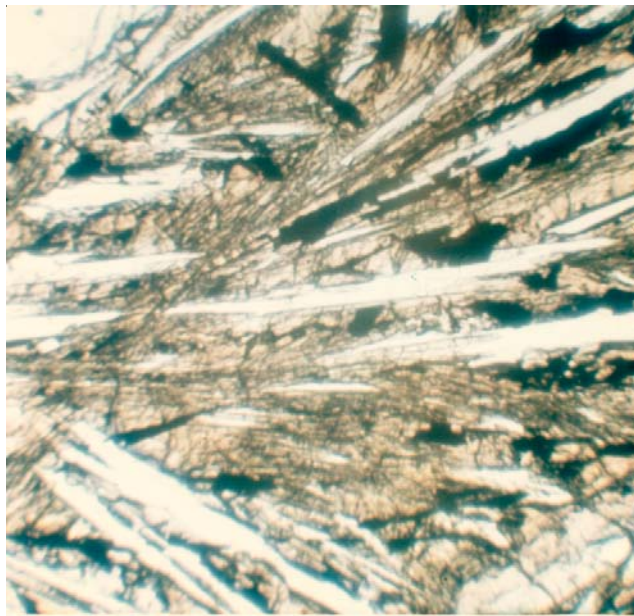

Figure 3: Photomicrographs of thin section 12065,7 (plane-polarized light; crossed-nicols) showing finely intergrown sheaths of plagioclase, pyroxene and ilmenite. Field of view 0.8 mm. NASA #S69-63438-439.

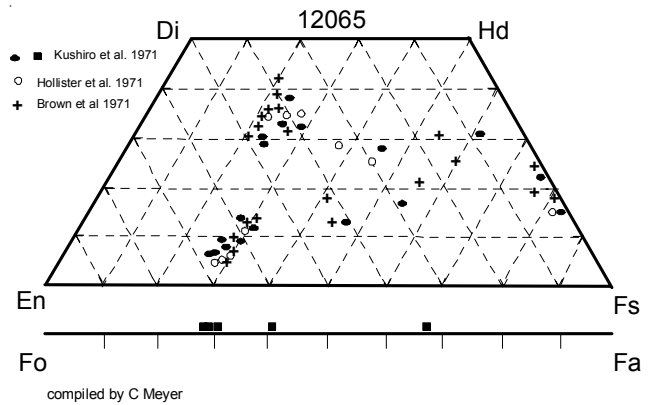

Figure 4: Pyroxene and olivine composition of 12065 (adapted from Kushiro et al. 1971, Brown et al. 1971 and Hollister et al. 1971).

ppm carbon in 12065. Lovering and Hughes (1971) determined Re and Os.

Radiogenic age dating

Turner (1971) determined 3.24 ± 0.05 b.y. by Ar/Ar (figure 8). Papanastassiou and Wasserburg (1971a) determined 3.16 ± 0.09 b.y. by Rb/Sr mineral isochron (figure 7). Alexander et al. (1972) determined 3.23 ± 0.03 b.y.

Cosmogenic isotopes and exposure ages

Rancitelli et al. (1971) determined the activity of ^{22}Na (32 dpm/kg), ^{26}Al (82 dpm/kg), ^{46}Sc (5.4dpm/kg), ^{48}V (7 dpm/kg), ^{54}Mn (31 dpm/kg) and ^{56}Co (22 dpm/kg). Hintenberger et al. (1971) determined exposure ages for 12065 using ^3He (180 m.y.), ^{21}Ne (200 m.y.) and ^{38}Ar (200 m.y.).

Other Studies

Fleischer et al. (1971) determined the nuclear track densities in pyroxene and estimated the surface residence time. Bogard et al. (1971) reported the content and isotopic composition of rare gases in

Mineralogical Mode for 12065

	Neal et al. 1994	Papike et al. 1976	Brown et al. 1971
Olivine	0.3	0.8	2.8
Pyroxene	68.6	70	68
Plagioclase	24.9	18.8	17
Opaques		10	11
Ilmenite	1.6		
Chromite +Usp	1.6		
mesostasis	2.1	0.1	
"silica"	0.5	0.3	

12065. Gromme and Doell (1971) and Hargraves and Dorety (1971) reported magnetic properties. Seismic wave velocities were determined as a function of pressure by Kanamori et al. (1971).

Processing

In 1970, a slab (,16) was cut through the middle of 12065 and two columns (,19 and ,20) were cut from the slab (figures 9 – 11). For some reason, 12065,15 is on public display in Huntsville, Alabama (figure 13).

There are 16 thin sections.

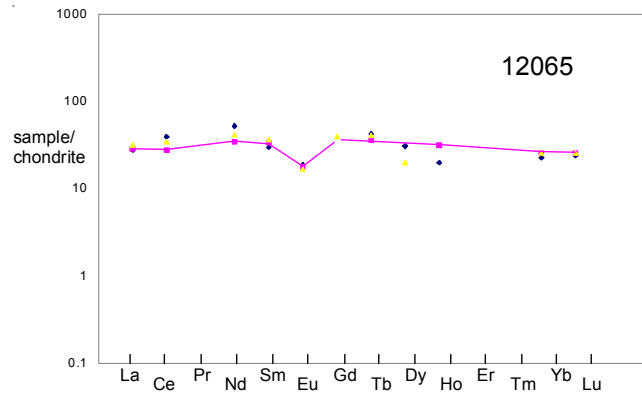

Figure 5: Normalized rare-earth-element composition diagram for 12065.

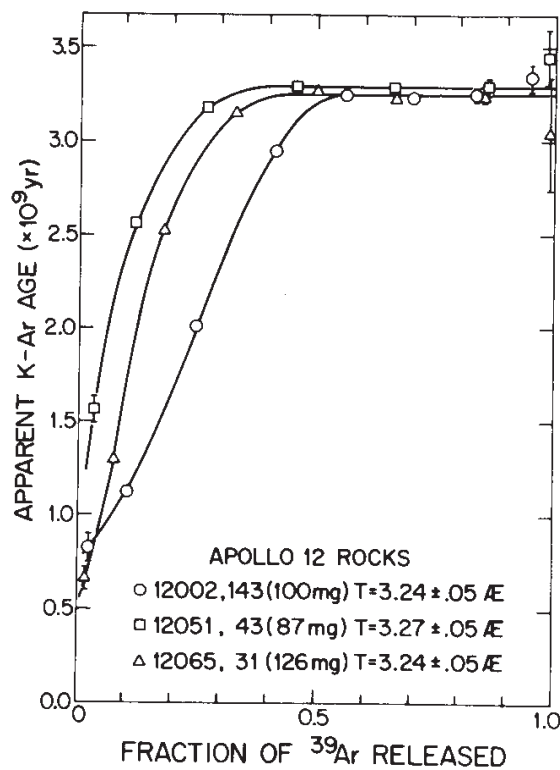

Figure 8: Ar-Ar release pattern for 12065 (from Turner 1971).

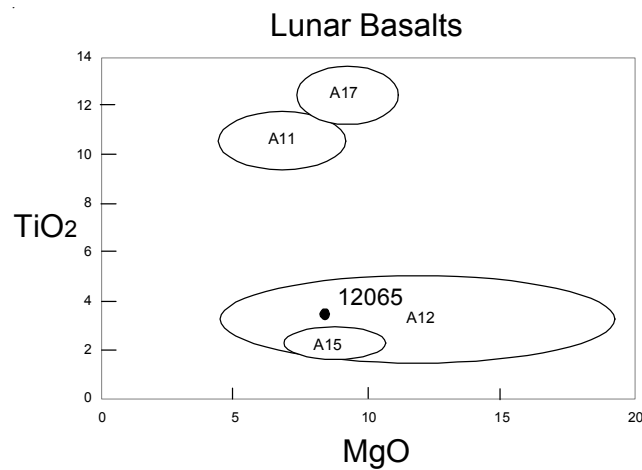

Figure 6: Composition of 12065 compared with that of other lunar basalts.

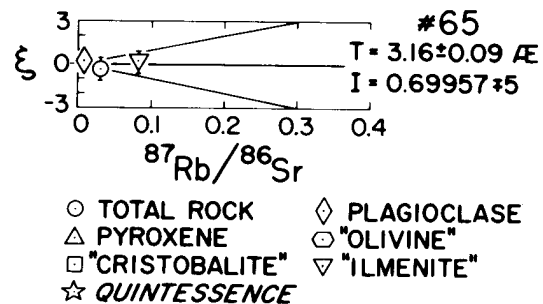

Figure 7: Rb-Sr isochron for 12065 (from Papanastassiou and Wasserburg 1971a).

Summary of Age Data for 12065

	Ar/Ar	Rb/Sr	Nd/Sm
Turner 1971	3.24 ± 0.05 b.y.		
Alexander et al. 1972	3.23 ± 0.03		
Papanastassiou and Wasserburg 1971a		3.16 ± 0.09	

Cation: Beware change in decay constants.

Table 1. Chemical composition of 12065.

reference weight	Maxwell71	Kushiro71 25 g 3.1 g	LSPET70	Goles71	O'Kelly71 2109 g	Wanke71	Anders71	Rancitelli71 1209 g
SiO ₂ %	46.87	46.61 46.14	(c) 39	44.9 (a)		46.85 (a)		
TiO ₂	3.34	3.15 3.34	(c) 3.8	3.1 (a)		3.5 (a)		
Al ₂ O ₃	10.05	10.58 10.73	(c) 12	9.2 (a)		10.33 (a)		
FeO	19.76	19.36 19.86	(c) 22	19.7 (a)		19.8 (a)		
MnO	0.256	0.26 0.26	(c) 0.41	0.26 (a)		0.29 (a)		
MgO	7.82	8.04 8.05	(c) 9			8.49 (a)		
CaO	10.73	11.13 10.96	(c) 12.6	11		10.8 (a)		
Na ₂ O	0.27	0.34 0.25	(c) 0.39	0.25		0.24 (a)		
K ₂ O	0.073	0.08 0.07	(c) 0.072		0.061 (d)	0.08 (a)		0.065 (d)
P ₂ O ₅	0.13	0.21						
S %								
sum								
Sc ppm	50.6 (b)		60	50 (a)		56.5 (a)		
V	150 (b)		135	180 (a)				
Cr		3284	3500	3090 (a)		3560 (a)		
Co	39 (b)		34			38.8 (a)	43 42	(e)
Ni	20 (b)		25					
Cu	15 (b)					7.8 (a)		
Zn							0.93 0.67	(e)
Ga								
Ge ppb								
As								
Se							0.2 0.18	(e)
Rb			0.72				1.15 1.05	(e)
Sr	89 (b)		135					
Y	43 (b)		48					
Zr	140 (b)		180					
Nb								
Mo								
Ru								
Rh								
Pd ppb								
Ag ppb							1.37	(e)
Cd ppb							1.2	(e)
In ppb							2.2	(e)
Sn ppb								
Sb ppb								
Te ppb								
Cs ppm							0.07 0.05	(e)
Ba			70	90 (a)				
La	7.5 (a)			6.9 (a)		6.68 (a)		
Ce	21 (a)			17 (a)		24 (a)		
Pr								
Nd	19 (a)			16 (a)		24 (a)		
Sm	5.5 (a)			5.02 (a)		4.5 (a)		
Eu	0.96 (a)			1.01 (a)		1.06 (a)		
Gd	7.8 (a)							
Tb	1.51 (a)			1.3 (a)		1.58 (a)		
Dy	4.9 (a)					7.64 (a)		
Ho				1.8 (a)		1.11 (a)		
Er								
Tm	0.69 (a)							
Yb	4.3 (a)			4.15 (a)		3.78 (a)		
Lu	0.64 (a)			0.64 (a)		0.59 (a)		
Hf	2.8 (a)			3.58 (a)		3.9 (a)		
Ta	0.68 (a)			0.39 (a)		0.51 (a)		
W ppb								
Re ppb								
Os ppb								
Ir ppb							0.08 0.05	(e)
Pt ppb								
Au ppb								
Th ppm					1.06 (d)		0.01 0.01	(e)
U ppm					0.27 (d)			0.991 (d) 0.282 (d)

technique: (a) INAA, (b) OES, (c) conventional wet, (d) radation counting, (e) RNAA

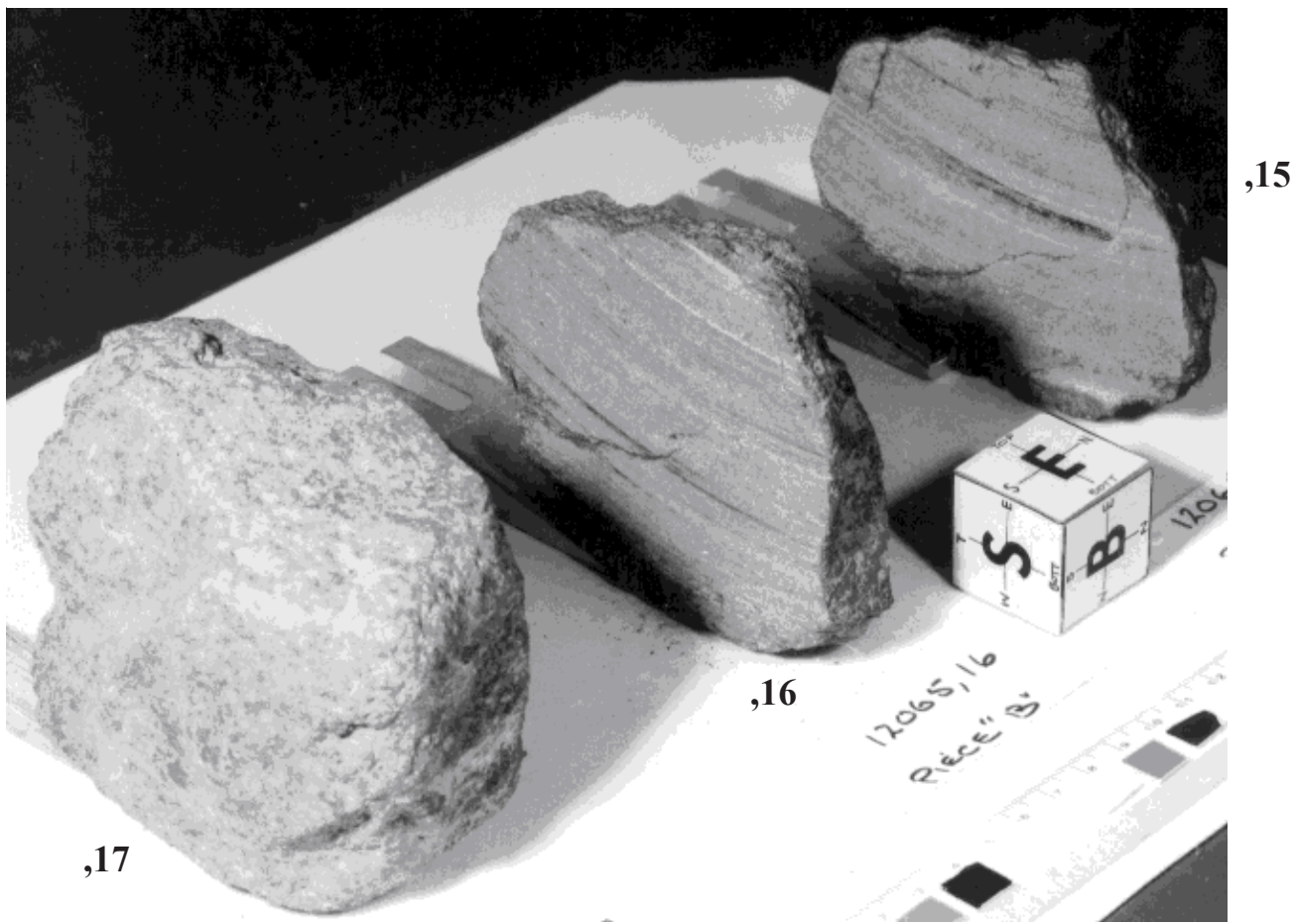

Figure 9: Group photo of 12065 after sawing slab. NASA # S70-37260.

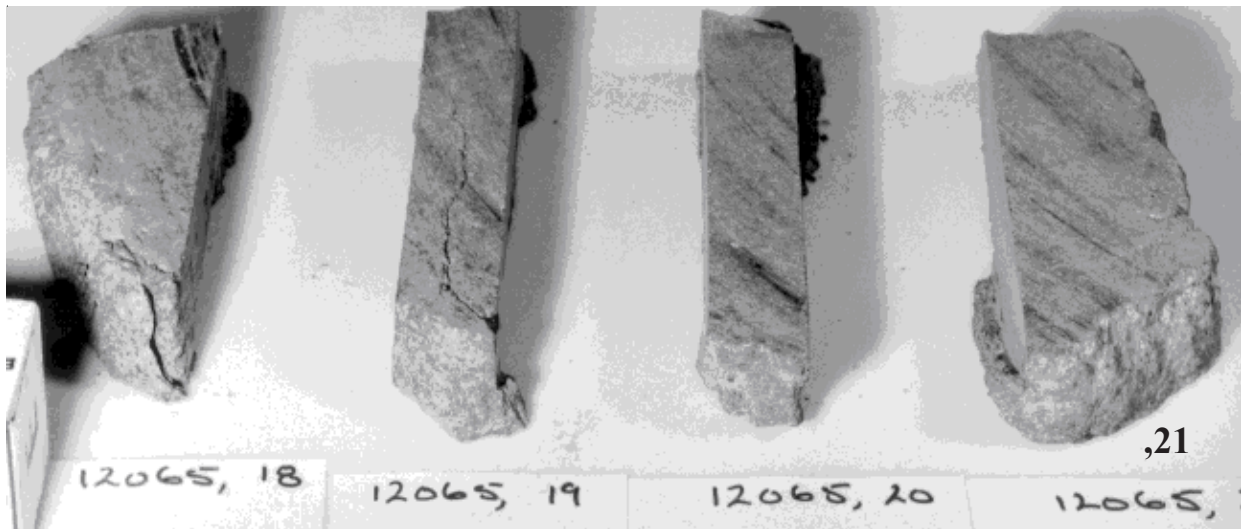
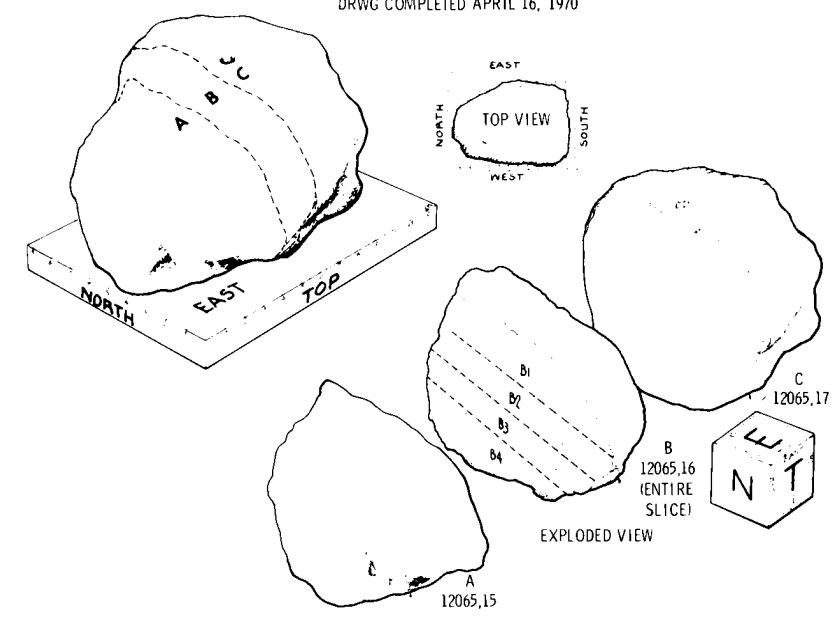

Figure 10: Group photo of columns cut from slab 12065,16. Thickness of slab is 1.6 cm. NASA # S70-37272.

DRWG COMPLETED APRIL 16, 1970



THE CUTTING OF SLICE 'B1' NO. 12065,21

DRWG COMPLETED APRIL 17, 1970

REVISION NO. 1
5/21/70

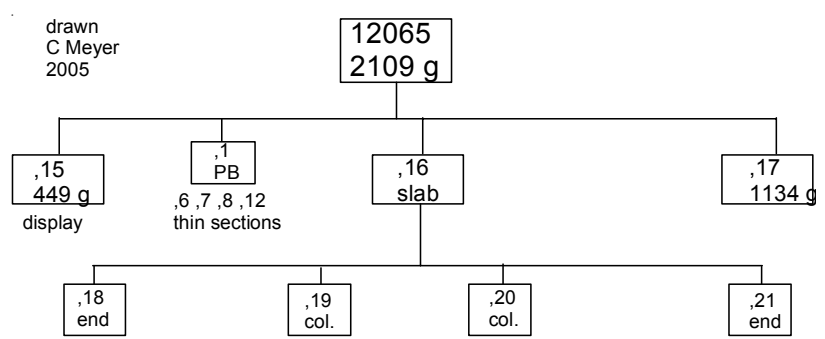
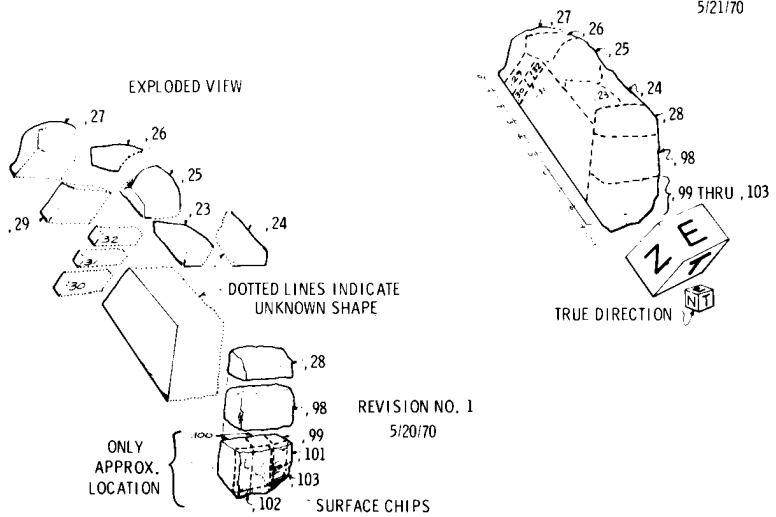

DRWG COMPLETED APRIL 20, 1970

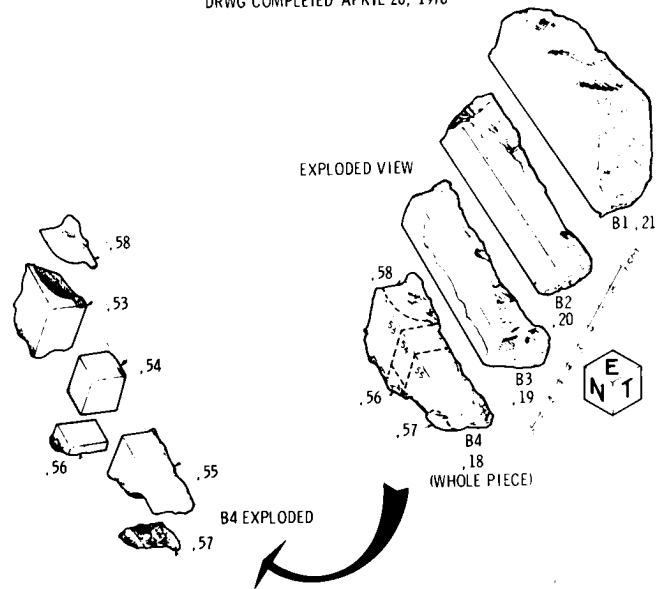

THE CUTTING OF SLICE 'B2' NO. 12065,20

DRWG COMPLETED APRIL 22, 1970

REVISION NO. 1
5/21/70

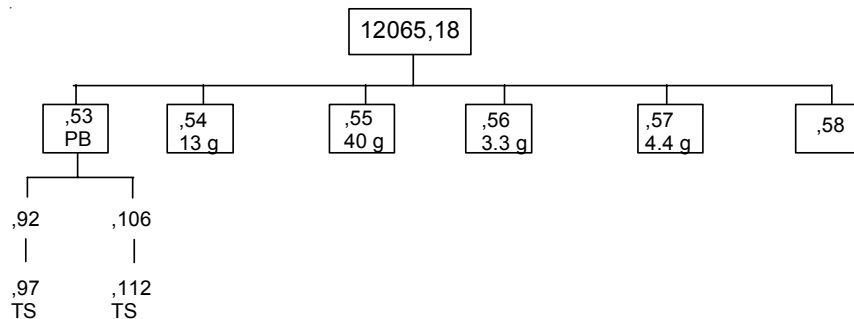
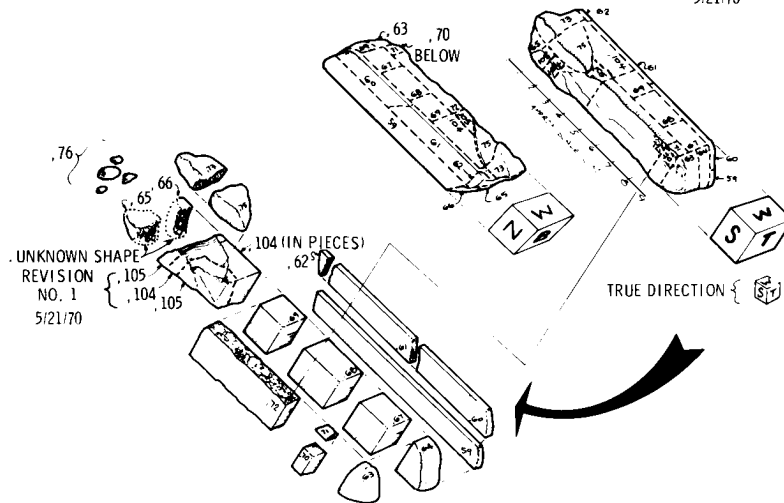

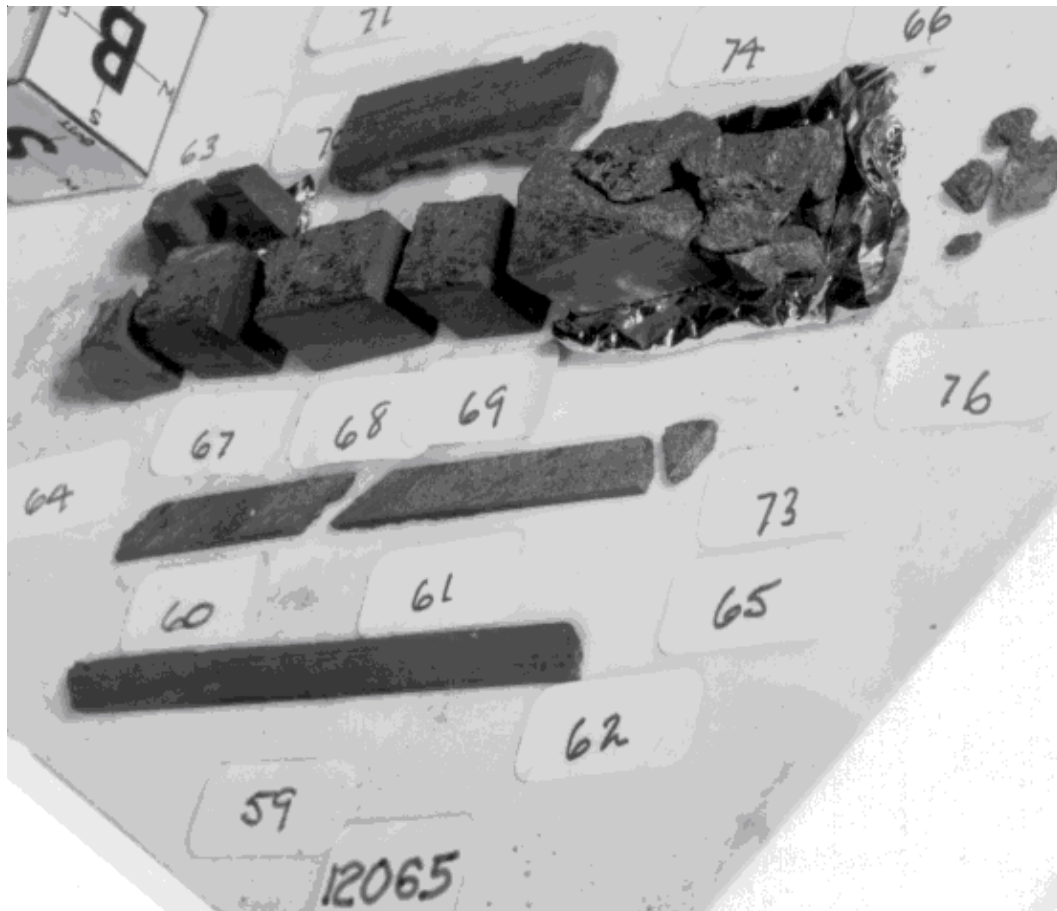

Figure 11: Group photo of column (,20) cut from slab 12065,16. NASA # S70-37268.

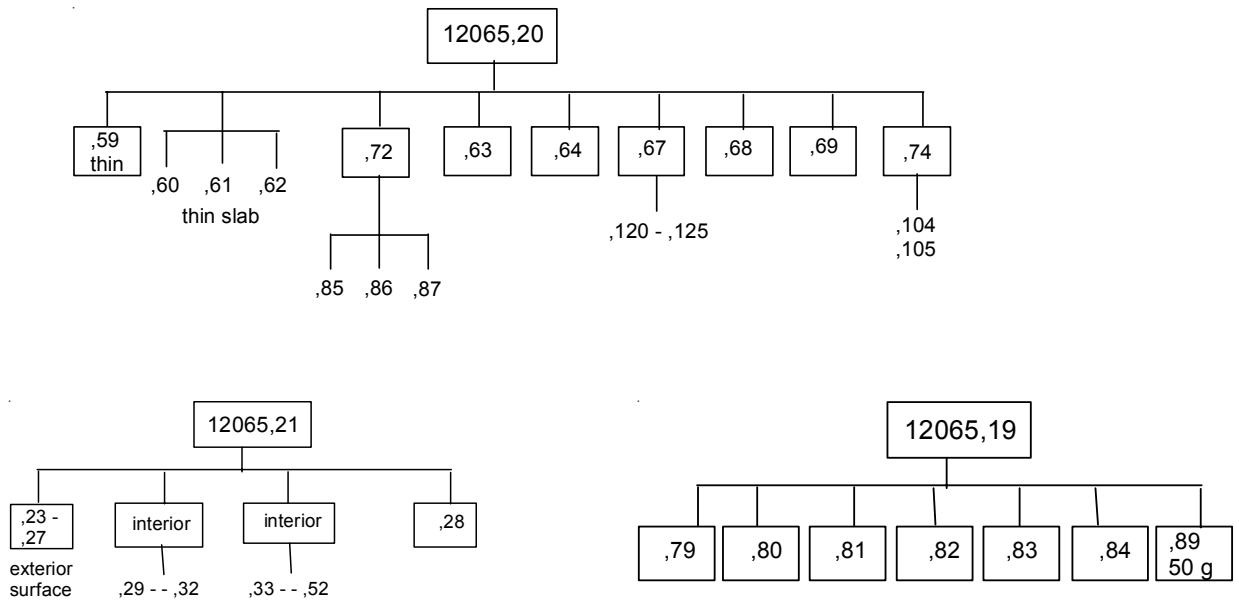



Figure 13: 12065,15 on display. NASA # S89-35328.

List of Photo #s of 12065

S69-23361	TS
S69-23363	
S69-23376	
S69-23378	
S69-63405	
S69-63630	
S69-63438 – 63439	TS color
S69-64880	
S69-61665 – 61666	
S69-60573 – 60596	B & W mug
S70-20737	TS
S70-37260	processing
S70-37268	processing
S70-37272	processing
S70-40815	TS best
S70-40824	TS
S70-49850 – 49857	TS color
S89-35328 – 35330	display

References for 12065

Anders E., Ganapathy R., Keays R.R., Laul J.C., and Morgan J.W. (1971) Volatile and siderophile elements in lunar rocks: Comparison with terrestrial and meteoritic basalts. *Proc. 2nd Lunar Sci. Conf.* 1021-1036.

Anders E., Ganapathy R., Krahenbuhl U. and Morgan J.W. (1973) Meteoritic material on the Moon. *The Moon* **8**, 3-24.

Alexander E.C., Davis P.K. and Reynolds J.H. (1972) Rare-gas analysis on neutron irradiated Apollo 12 samples. *Proc. 3rd Lunar Sci. Conf.* 1787-1795.

Bogard D.D., Funkhouser J.G., Schaeffer O.A. and Zahringer J. (1971) Noble gas abundances in lunar material-cosmic ray spallation products and radiation ages from the Sea of Tranquillity and the Ocean of Storms. *J. Geophys. Res.* **76**, 2757-2779.

Bouchet M., Kaplan G., Voudon A., and Bertolotti M.-J. (1971) Spark source spectrometric analysis of major and minor elements in six lunar samples. *Proc. 2nd Lunar Sci. Conf.* 1247-1252.

Fleischer R.L., Hart H.R., Comstock G.M. and Evwarate A.O. (1971) The particle track record of the Ocean of Storms. *Proc. 2nd Lunar Sci. Conf.* 2559-2568.

Gay P., Brown M.G., Muir I.D., Bancroft G.M. and Williams PGL (1971) Mineralogical and petrographic investigations of some Apollo 12 samples. *Proc. Second Lunar Sci. Conf.* 377-392.

Goles G.G., Duncan A.R., Lindstrom D.J., Martin M.R., Beyer R.L., Osawa M., Randle K., Meek L.T., Steinborn T.L. and McKay S.M. (1971) Analyses of Apollo 12 specimens: Compositional variations, differentiation processes, and lunar soil mixing models. *Proc. 2nd Lunar Sci. Conf.* 1063-1081.

Gromme C.S. and Doell R.R. (1971) Magnetic properties of Apollo 12 lunar samples 12052 and 12065. *Proc. Second Lunar Sci. Conf.* 2491-2499.

Hintenberger H., Weber H.W. and Takaoka N. (1971) Concentrations and isotopic abundances of the rare gases in lunar matter. *Proc. 2nd Lunar Sci. Conf.* 1607-1625.

- Hollister L.S., Trzcinski W.E., Hargraves R.B. and Kulick C.G. (1971) Petrogenetic significance of pyroxenes in two Apollo 12 samples. *Proc. Second Lunar Sci. Conf.* 529-557.
- James O.B. and Wright T.L. (1972) Apollo 11 and 12 mare basalts and gabbros: Classification, compositional variations and possible petrogenetic relations. *Geol. Soc. Am. Bull.* **83**, 2357-2382.
- Kanamori H., Mitzutani H. and Hamano Y. (1971) Elastic wave velocities of Apollo 12 rocks at high pressure. *Proc. Second Lunar Sci. Conf.* 2323-2326.
- Kushiro I. and Haramura H. (1971) Major element variation and possible source materials of Apollo 12 crystalline rocks. *Science* **171**, 1235-1237.
- Kushiro I., Nakamura Y., Kitayama K. and Akimoto S-I. (1971) Petrology of some Apollo 12 crystalline rocks. *Proc. 2nd Lunar Sci. Conf.* 481-495.
- Lovering J.F. and Hughes T.C. (1971) Re and Os determinations and meteoritic contamination levels in Apollo 11 and Apollo 12 lunar samples. *Proc. Second Lunar Sci. Conf.* 1331-1335.
- LSPET (1970) Preliminary examination of lunar samples from Apollo 12. *Science* **167**, 1325-1339.
- Maxwell J.A. and Wiik H.B. (1971) Chemical composition of Apollo 12 lunar samples 12004, 12033, 12051, 12052 and 12065. *Earth Planet. Sci. Lett.* **10**, 285-288.
- Moore C.B., Lewis C.F., Larimer J.W., Delles F.M., Gooley R.C., Nichiporuk W. and Gibson E.K. (1971) Total carbon and nitrogen abundances in Apollo 12 lunar samples. *Proc. 2nd Lunar Sci. Conf.* 1343-1350.
- O'Kelley G.D., Eldridge J.S., Schonfeld E. and Bell P.R. (1971a) Abundances of the primordial radionuclides K, Th, and U in Apollo 12 lunar samples by nondestructive gamma-ray spectroscopy: implications for the origin of lunar soils. *Proc. Second Lunar Sci. Conf.* 1159-1168.
- O'Kelley G.D., Eldridge J.S., Schonfeld E. and Bell P.R. (1971b) Cosmogenic radionuclide concentrations and exposure ages of lunar samples from Apollo 12. *Proc. Second Lunar Sci. Conf.* 1747-1755.
- Papanastassiou D.A. and Wasserburg G.J. (1971a) Lunar chronology and evolution from Rb-Sr studies of Apollo 11 and 12 samples. *Earth Planet. Sci. Lett.* **11**, 37-62.
- Papike J.J., Hodges F.N., Bence A.E., Cameron M. and Rhodes J.M. (1976) Mare basalts: Crystal chemistry, mineralogy and petrology. *Rev. Geophys. Space Phys.* **14**, 475-540.
- Rancitelli L.A., Perkins R.W., Felix W.D. and Wogman N.A. (1971) Erosion and mixing of the lunar surface from cosmogenic and primordial radionuclide measurement in Apollo 12 lunar samples. *Proc. 2nd Lunar Sci. Conf.* 1757-1772.
- Reid J.B. (1971) Apollo 12 spinels as petrogenetic indicators. *Earth Planet. Sci. Lett.* **10**, 351-356.
- Smales A.A., Mapper D., Webb M.S.W., Webster R.K., Wilson J.D., and Hislop J.S. (1971) Elemental composition of lunar surface material (part 2). *Proc. Second Lunar Sci. Conf.* 1253-1258.
- Sutton R.L. and Schaber G.G. (1971) Lunar locations and orientations of rock samples from Apollo missions 11 and 12. *Proc. 2nd Lunar Sci. Conf.* 17-26.
- Turner G. (1971) ⁴⁰Ar-³⁹Ar ages from the lunar maria. *Earth Planet. Sci. Lett.* **11**, 169-191.
- Wänke H., Wlotzka F., M. and Rieder R. (1971) Apollo 12 samples: Chemical composition and its relation to sample locations and exposure ages, the two component origin of the various soil samples and studies on lunar metallic particles. *Proc. 2nd Lunar Sci. Conf.* 1187-1208
- Warner J. (1970) Apollo 12 Lunar Sample Information. NASA TR R-353. JSC (catalog)