

15405
Breccia
513.1 grams



Figure 1: Boulder where 15405 was collected. Boulder is about 3 meters across. AS15-90-12199

Transcript

LMP - - let me hold that Rover (figure 2) and you come up and look at this, because this rock has got green in it, a light green color. Come on. The first green rock I've seen – light green.

CC Dave and Jim, use your best judgment here, the block's not all that important - -

CDR No, we're okay. It's just that this slope's pretty steep (15 deg), and I cannot take too much time – here. It's a big breccia – that's all it is.

LMP About halfway up, maybe you have to look down-sun to see it. It looks like a light green layer, not necessarily a thick layer. Light green.

CDR You mean on the surface?

LMP Yes, on the surface.

CDR Hey, you're right. —

LMP This rock is about 3 meters long. Subangular – very rough surface. And the surface that's facing northwest is the dark, typical breccias. And it looks like – what appeared to me like there's a layer that might be a foot and a half thick, appears a light greenish color. Dave's sampling right now. And on the side to the southeast is again the breccia isn't that right Dave?

CDR Yes, and I got a little fragment. Don't drop it. There. And I got some green, and I got a fragment out of the breccia. It's fairly loose breccias, as breccias go. Oh, and there's a great big white clast on the inside, but – man, like an inch or so (bag 168). And I think we'll call it quits on that one.

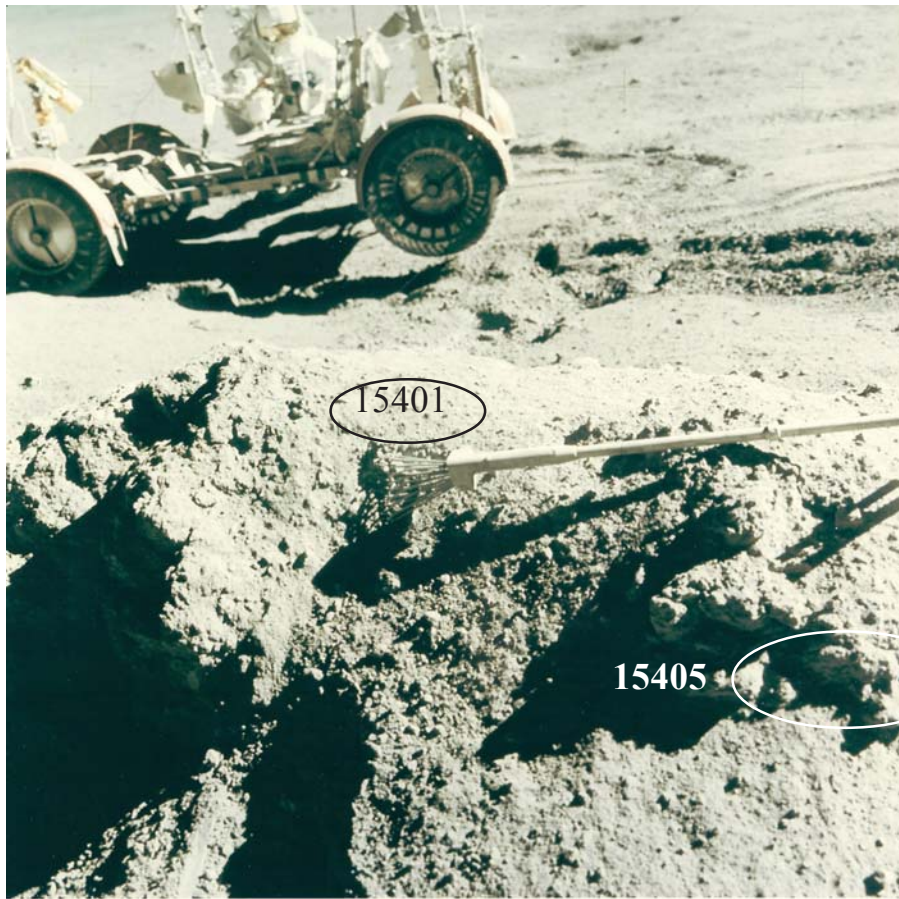

Figure 2: Surface photo of boulder where 15401 and 15405 were collected. AS15-86-11659.

Introduction

15405 was chipped from a prominent boulder (3 meter) at station 6A on the Apennine Front (figures 1 and 2). Station 6A was the highest point reached on the Apennine Front (about 100 meters above the level of the LM). The astronauts described the boulder as a “big breccia” and remarked on abundant green material (see transcript). They sampled a portion of the boulder (15405) and collected a soil sample from the top of the boulder (15401).

Swann et al. (1972) remark that “*although the boulder lies 250 meters from Spur Crater, it closely resembles samples 15445 and 15455, which were collected at Spur Crater, and the greenish-gray soils resemble friable, green rocks and green soils collected at Spur Crater. Hence, it is possible that the boulder was ejected from Spur Crater, or at least that it was derived from the same type of material that was excavated by the Spur Crater event.*” The boulder has a deep fillet on the South, uphill side.

Marvin (1976) describes sample 15405 as a “rough and angular, welded mass of small, blocky slabets”. It was returned broken into several fragments (figure 3), but the main mass was found to be tough and required sawing to obtain interior pieces (figure 4 and 5).

15405 was first studied by a consortium led by Rama Murthy, then by the “Imbrium Consortium” (led by Wood and Marvin). Early work is nicely summarized by Graham Ryder (1985), but a complete description of 15405 remains unpublished. Zircons from this sample have been found to be old, but the age of the breccia-forming event is young (~1.3 b.y.?).

Both 15405 and 15205 are both KREEP-rich breccias chipped from two different boulders on the lower slope of the Apennine Front.

Petrography

15405 is a clast-bearing impact-melt rock with a crystalline matrix made up of fine-grained intergrown



Figure 3: Initial PET photograph of 15405. NASA # S71-44126. Note that 15405 is made of several pieces.

pyroxene, plagioclase and ilmenite laths (figure 6). Prominent clasts include mineral fragments of plagioclase and pyroxene (figure 7), along with lithic clasts of KREEP basalt, granite and quartz monzodiorite (QMD). Flow banding in the matrix includes small irregularly-shaped vugs (figure 5).

The clast population of 15405 generally lacks fragments of mare basalt, glass, anorthosite, norite or troctolite, but is instead rich in KREEP basalt. Warren (1993) lists four apparently pristine clasts from 15405 that have been studied (two alkaline suite and two KREEP-like).

The KREEP basalt clasts are described by Ryder and Bower (1976) and Ryder (1976). They have fine-grained subophitic texture (figure 8) with about equal amounts of plagioclase and zoned pyroxene (figure 9) and were found to be similar to Apollo 15 KREEP basalts (see section on 15382). *No large clasts of KREEP basalt were found or studied from 15405.*

Three large clasts of quartz monzodiorite (QMD) were analyzed and described Ryder (1976), Taylor et al. (1980) and Takeda et al. (1981). QMD clast A was large (~1 cm; 2.5 grams) and coarse-grained (figure 10) and includes subsamples ,56 ,57 ,85 etc. QMD clast B was extracted from slab ,95 (figure 19) and includes subsamples ,110 ,115 . 15405,145 is a thin section with a small portion of QMD clast B (figure 14). Taylor et al. (1980) estimate the mineral mode of QMD as 35% each of plagioclase and pyroxene, 10-15% each of silica and K-feldspar and 0.5 to 1% each of zircon, ilmenite, whitlockite and minor chromite and Fe metal. The pyroxene in 15405 QMD is Fe-rich and unzoned, but exsolved (figure 11). Takeda et al. (1981) studied pyroxene exsolution in QMD.

Granite clasts were reported, but it is unclear whether they are remelted QMD or not (Ryder 1976). McGee et al. (1978) describe granite clasts as coarse-grained (>1 mm) and typically crushed or melted. They consist of untwined plagioclase, clinopyroxene, cristobalite (?), and K-feldspar. Ilmenite, Fe-metal, troilite, chromite

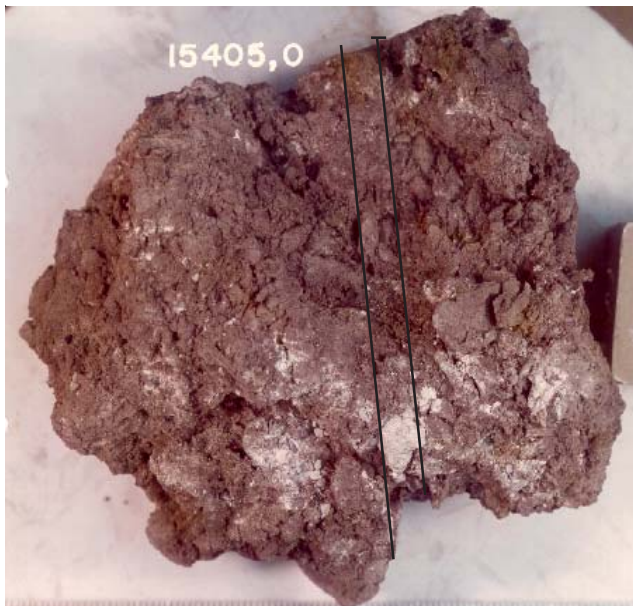

Figure 4a: Photo of largest piece of 15405,0 (T1 surface). NASA # S75-21518. End to end is ~ 7 cm. Position of saw cuts for slab (.92 ,95) are shown.



Figure 4b: Photo of 15405,0 (B1 surface). NASA # S75-21519. Cube is 1 inch.



Figure 5: Photo of sawn surface of 15405,0 showing clasts and 'flow-banding' in matrix. S85-38199. Sample is about ~ 9 cm long and prominent white clast is ~ 0.9 cm long.

and phosphate are present in minor amounts. *No large clasts of "granite" were found or studied from 15405.*

Clast ,170 (chipped from ,0) is a feldspathic alkali norite with plutonic texture and very high trace element content studied by Lindstrom et al. (1988) and Marvin

et al. (1991). Cumulus plagioclase (An_{89} ; 0.6 mm) and pigeonite (En_{61} ; 1 mm) are enclosed in post cumulate plagioclase and pyroxene (see figure 15).

Clast ,181 (chipped from ,0) is a cataclastic alkali anorthosite studied by Lindstrom et al. (1988). It is

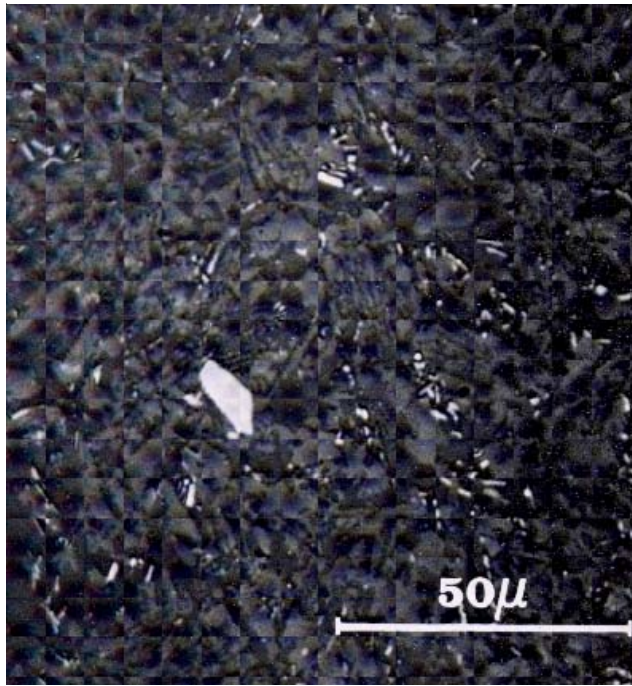

Figure 6: Reflected light photo of thin section of 15405 showing that matrix is made up of interlocking pyroxene and plagioclase laths.

mostly granulated plagioclase (An_{84} ; 0.6 mm), with minor ilmenite and rare phosphate, but contains no pyroxene (see figure 16).

Ryder and Bower (1976) also briefly describe small clasts of “olivine vitrophyre” in thin section descriptions.

The close association of QMD and KREEP basalts in this breccia, along with similar REE patterns, led Ryder

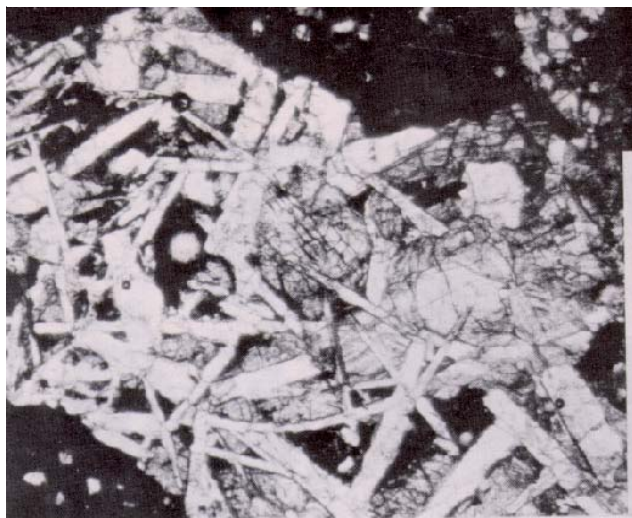

Figure 8: Photomicrograph of KREEP basalt clast in 15405 (from Ryder 1976).

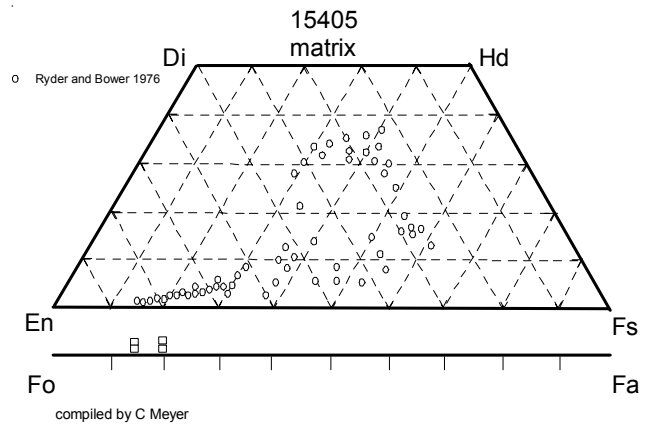

Figure 7: Composition diagram of pyroxene crystals in matrix of 15405.

(1976) to suggest there might be a “close association” of QMD with KREEP basalt. But we now know the ages of KREEP basalt are about 3.9 b.y, while the initial age of the QMD was about 4.3 b.y. Thus, this “association” is unlikely. Rutherford et al. (1976) discuss silicate liquid immiscibility as a process leading to QMD, but Ryder (1976) and Taylor et al. (1980) found the chemical evidence against an origin by liquid immiscibility.

Chemistry

The bulk composition of the matrix is similar to that of KREEP basalt (table 1 and figure 16). The composition of individual clasts in 15405 is given in table 2 and figure 14. The high REE content of the norite clast is due to a large whitockite grain and probably not representative. A number of clasts are pristine ($Ir < 0.1$ ppb) and even the matrix is relatively low in meteoritic siderophiles.

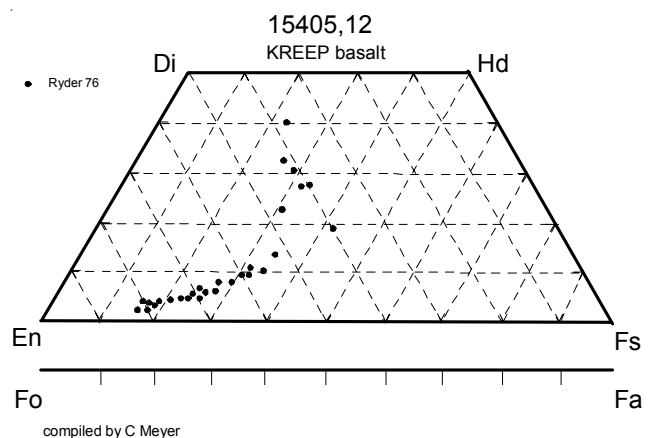

Figure 9: Pyroxene in KREEP basalt fragments found in thin section only in 15405 (from Ryder 1976).

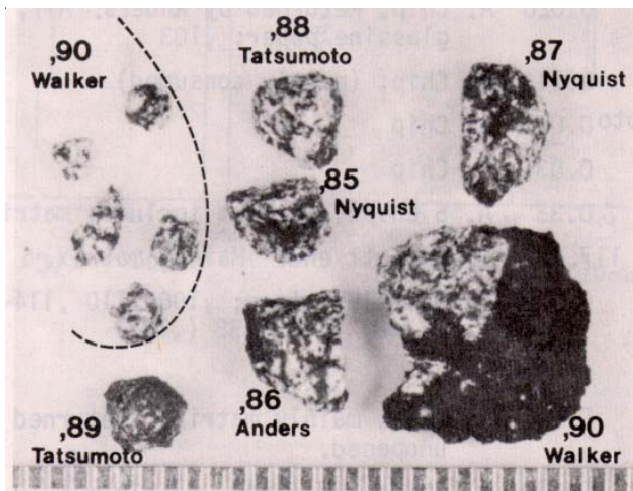

Figure 10: Processing photo of quartz monzodiorite (QMD) clast A (from Ryder 1979).



Figure 12: Photomicrograph of QMD 15405,56 (clast A) (from Ryder 1976).

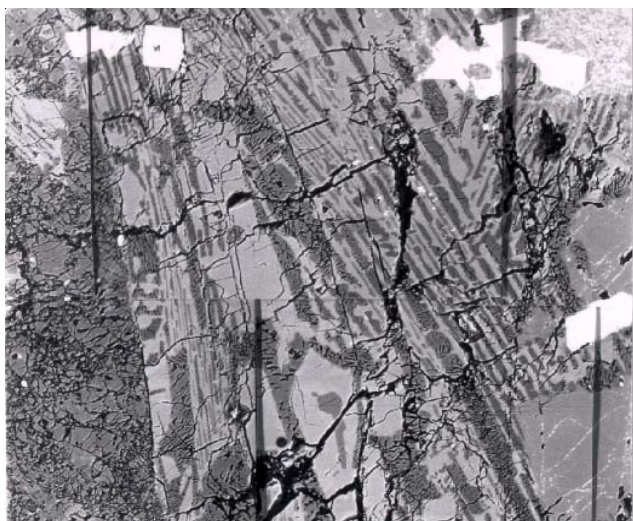

Figure 14: Backscattered electron (BSE) image of granitic portion of QMD 15405,145 (clast B), showing lace-like intergrowth of K-feldspar and silica. Bright grains are zircons (from Meyer et al. 1996). Field of view is 2 mm.

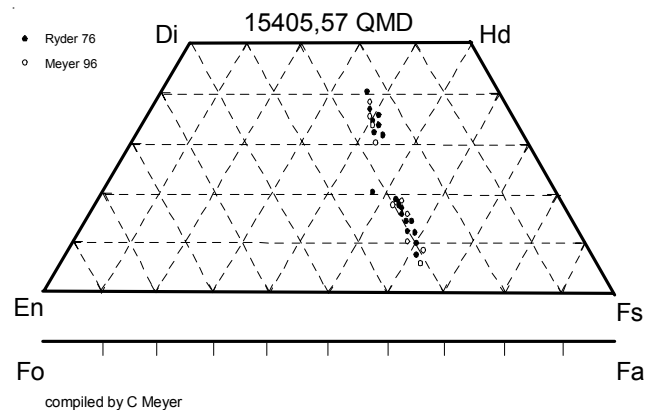

Figure 11: Pyroxene composition in 15405,57 and ,145 quartz monzodiorite (from Ryder 1976 and Meyer 1996).

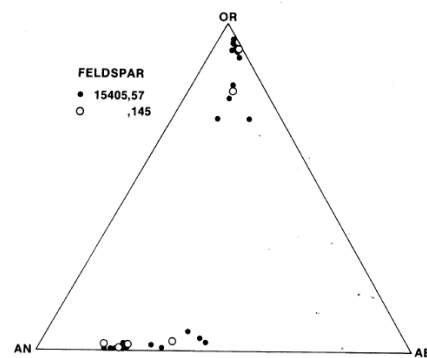

Figure 13: Composition diagram of feldspars in two clasts of QMD (from Meyer et al. 1996).

Radiogenic age dating

Bernatowicz et al. (1978) used the $^{39}/^{40}$ Ar plateau age method to attempt to date the matrix and the QMD clast (figure 18). Nyquist et al. (1977) attempted to date QMD by Rb/Sr and found that the Sr was highly radiogenic, but could not obtain a well defined age. Tatsumoto and Unruh (1976) used U/Pb techniques, but found that the Pb was disturbed and could not obtain an age. Finally, Meyer et al. (1996) used the ion microprobe U/Pb technique to date zircons intergrown with other phases *in situ* in thin sections of QMD clasts A and B (figure 17).

Cosmogenic isotopes and exposure ages

Drozd et al. (1976) determined an exposure age of 11 ± 1.1 m.y. by ^{81}Kr and 6 m.y. by ^{21}Ne .

Other Studies

Rare gas studies are reported in Drozd et al. (1976).

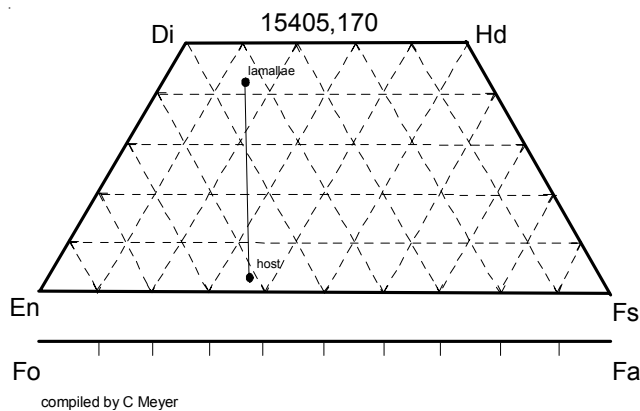

Figure 15: Composition diagram of pyroxene in alkali norite (AN) clast in 15405,170 (from Lindstrom et al. 1988).

Fleischer and Hart (1972, 1973) and Podosek and Walker (1976) measure fission track density and U in the matrix.

Processing

Initially several large pieces (,4 ,5 ,6 ,7 ,8) broke off of the rock (see flow diagram). Sample 15405,5 was allocated for consortium study led by Rama Murthy and was analyzed by Laul and Schmitt (1972,1973). The main piece, termed 15405,0, was sawn in 1975 to create a slab, which broke in two main pieces (,95 and

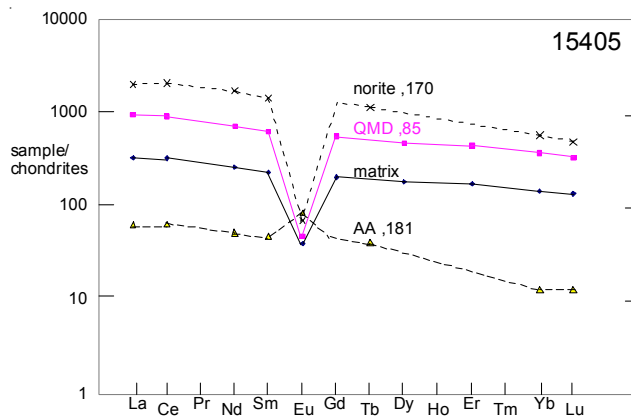

Figure 16: Normalized rare-earth-element diagram for matrix and clasts in 15405. Data from Nyquist et al. (1976) and Lindstrom et al. (1988). Sample-split 15405,170 is called an "alkali norite", but must include a large whitlockite grain.

,92). One butt end (, 91) is in remote storage. Processing of the rock was documented by the Imbrium Consortium, led by John Wood and Ursula Marvin, in their 1976 and 1977 reports. Graham Ryder consolidated all this information in his 1985 catalog, which represent the only decent published account (to date) of this complex sample.

There are 37 thin sections of 15405.

Summary of Age Data for 15405

	Ar/Ar
Bernatowicz et al. 1978	1.29 ± 0.04 b.y.
Meyer et al. 1996	

	U/Pb
	4.294 ± 0.026 and 1320 ± 0.250

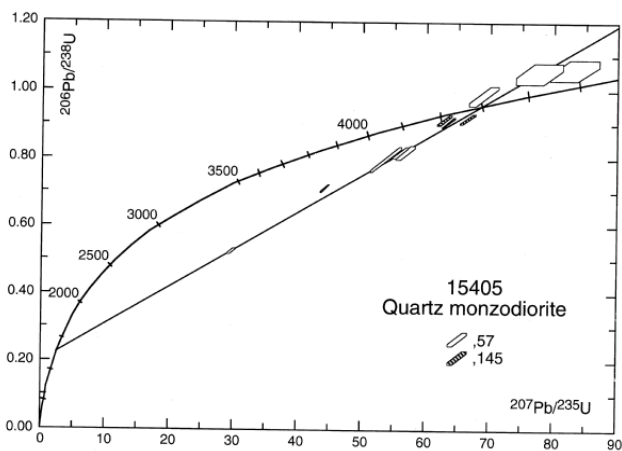

Figure 17: U-Pb concordia diagram for two QMD clasts in 15405 (from Meyer et al. 1996). Data collected by SHRIMP ion microprobe analyses of zircons needles found in thin section. The two intercepts at 4.3 b.y. and 1.3 b.y. are thought to be the time of initial crystallization of QMD and Pb-loss at subsequent breccia formation.

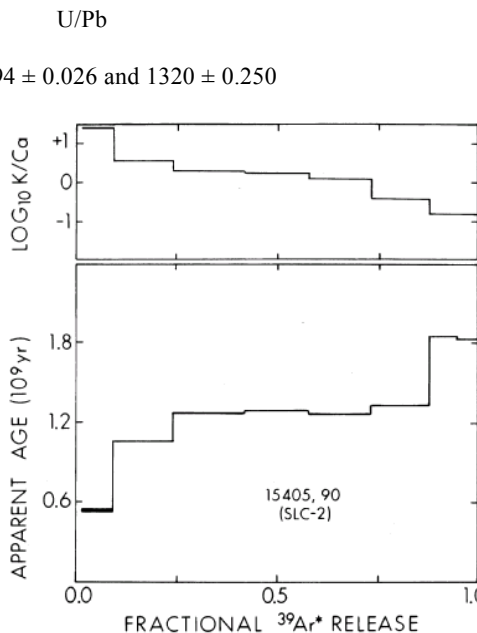

Figure 18: Ar plateau for QMD clast in 15405 (by Bernatowicz et al. 1978).

Table 1. Chemical composition of 15405 matrix.

reference weight	sawdust			,117		impact melt			average melt	
	Laul 73 191 mg	Christian 76	Nyquist 76 46 mg	Ganapathy 73	Gros 76	Lindstrom 88		Marvin 91		
SiO ₂ %		51.49	(a)			,173	,174	,175		
TiO ₂	1.2	(c) 1.8	(a)			1.99		2.03	1.94	(c)
Al ₂ O ₃	13.8	(c) 15.44	(a)			14.8		15.5	15.5	(c)
FeO	12.8	(c) 11.17	(a)			10.9	10.8	10.1	10.8	(c)
MnO	0.183	(c) 0.19	(a)							
MgO	14	(c) 7.33	(a)			7.3		8.4	7.8	(c)
CaO	10.3	(c) 9.98	(a)			10.3	9.4	10.5	10.2	(c)
Na ₂ O	0.547	(c) 0.81	(a)			0.856	0.861	0.829	0.86	(c)
K ₂ O	0.4	(c) 0.82	(a)	0.71	(d)			1.2	0.98	(c)
P ₂ O ₅		0.72	(a)							
S %										
sum										
Sc ppm	23	(c) 23	(a)			22.3	22.1	20.7	22.1	(c)
V	91	(c) 22	(a)							
Cr	2050	(c) 1505	(a)			1630	1580	2000	1700	(c)
Co	36	(c) 9.8	(a)			18.4	17.7	20.8	18.5	(c)
Ni		43	(a)		83	(b) 60	45	50		
Cu		6.8	(a)							
Zn		4.1	(a)	4.1	4.2	(b)				
Ga		4	(a)							
Ge ppb				94	62.6	(b)				
As										
Se				89	78	(b)				
Rb			20.5	(d) 25.6	27.4	(b) 24	29	19	24	(c)
Sr		190	(a) 168	(d)		190	180	150	173	(c)
Y		360	(a)							
Zr	500	(c) 1100	(a)			1100	1100	800	990	(c)
Nb		80	(a)							
Mo										
Ru										
Rh										
Pd ppb					1.7	(b)				
Ag ppb				2.9	2.22	(b)				
Cd ppb				16	17.7	(b)				
In ppb				1	1.47	(b)				
Sn ppb										
Sb ppb				0.067	1.06	(b)				
Te ppb				2.1	4.9	(b)				
Cs ppm				1.16	1.12	(b) 1.05	1.05	0.75	0.95	(c)
Ba	480	(c) 1200	(a) 767	(d)		880	880	680	845	(c)
La	46	(c) 55	(a) 78.7	(d)		83.4	87.3	67.6	78.2	(c)
Ce	114	(c)	197	(d)		222	229	180	215	(c)
Pr										
Nd			120	(d)		130	137	105	128	(c)
Sm	20.9	(c)	34.2	(d)		37.5	38.9	29.9	36.5	(c)
Eu	1.45	(c)	2.27	(d)		2.34	2.39	2.39	2.39	(c)
Gd			40.3	(d)						
Tb	3.6	(c)				7.95	8.24	6.45	7.99	(c)
Dy			44.2	(d)						
Ho										
Er			28	(d)						
Tm										
Yb	14	(c) 32	(a) 23.5	(d)		27.5	28	21.7	25.9	(c)
Lu	2.1	(c)	3.32	(d)		3.75	3.8	2.9	3.59	(c)
Hf	16.2	(c)				31.2	29.5	23.9	28.6	(c)
Ta	2	(c)				3.5	3.6	2.82	3.4	(c)
W ppb										
Re ppb				0.147	0.121					
Os ppb					1.16					
Ir ppb				1.64	1.28	<2	<2	<2		
Pt ppb										
Au ppb				0.93	0.525	1.5	<2	<2		
Th ppm	10	(c)				16	16.2	11.6	15.1	(c)
U ppm	2.3	(c)		5.1	4.69	(b) 4.29	4.43	3.14	4.19	(c)

technique (a) combined XRF, semimicro chem., emiss. Spec., (b) RNAA, (c) INAA, (d) IDMS

Table 2. Chemical composition of 15405 clasts.

reference weight	QMD	,85	,85	QMD	white c	Alk Anor	Akl Norite	Im melt	KREEP bas granite	
	Taylor 80	Nyquist 76 17 mg	Ryder 79	Gros 1976	Ganapathy 73	Lindstrom 88			Ryder 76	
SiO ₂ %						,181	,170	,171	,12	,12
TiO ₂	2.6 (a)						0.36	0.38	(a) 0.69	68 (d)
Al ₂ O ₃	11.9 (a)					30.4		22.8	(a) 16.25	10.15 (d)
FeO	14.1 (a)		15.1 (a)			0.302	4.3	8.61	(a) 8.48	6.99 (d)
MnO	0.18 (a)								(a) 0.07	0.12 (d)
MgO	3.8 (a)					1	4.4	7	(a) 10.54	1.53 (d)
CaO	8.9 (a)					17.6	16.4	13.3	(a) 9.44	4.89 (d)
Na ₂ O	0.81 (a)		0.87 (a)			0.91	0.86	0.537	(a) 0.72	0.79 (d)
K ₂ O	2.1 (a)	1.71	(b) 1.8 (a)					<0.8	(a) 0.53	3.39 (d)
P ₂ O ₅									0.25	0.52 (d)
S %										
sum										
Sc ppm	29 (a)		30.7 (a)			9.25	29.6	11.2	(a)	
V	33 (a)									
Cr			1220 (a)			570	1180	1130	(a)	
Co	8 (a)		7.8 (a)			18	10	11.6	(a)	
Ni				<2		(c) <50	<40	<40	(a)	
Cu						5	46		(a)	
Zn			60 (a)	6.3	4.9	(c)				
Ga										
Ge ppb				345	160	(c)				
As										
Se				89	104	(c)				
Rb		40.6		39	20.7	(c) <2	5	<12	(a)	
Sr		154				580	230	150	(a)	
Y										
Zr	1620					80	220	250	(a)	
Nb										
Mo										
Ru										
Rh										
Pd ppb										
Ag ppb				2.15	2.5	(c)				
Cd ppb				18.9	9.8	(c)				
In ppb				45.2	1	(c)				
Sn ppb										
Sb ppb				1.4	0.35	(c)				
Te ppb				9.4	1.9	(c)				
Cs ppm				1.19	0.925	(c) 0.19	0.26	0.1	(a)	
Ba	1900 (a)	1490 (b)				180	890	160	(a)	
La	183 (a)	224 (b)	210 (a)			15.1	470	20	(a)	
Ce	413 (a)	555 (b)	560 (a)			39.2	1254	52.4	(a)	
Pr										
Nd	287 (a)	328 (b)				24	780	27	(a)	
Sm	77.4 (a)	92 (b)	93 (a)			7.08	213	8.65	(a)	
Eu	2.75 (a)	2.69 (b)	2.52 (a)			4.85	4	1.16	(a)	
Gd		110 (b)								
Tb	14.9 (a)		19.7 (a)			1.48	42	1.85	(a)	
Dy	101 (a)	116 (b)								
Ho										
Er		71.7 (b)								
Tm										
Yb	55.2 (a)	60.9 (b)	65 (a)			2.08	94	6.66	(a)	
Lu	8.2 (a)	8.06 (b)	9 (a)			0.32	11.9	0.99	(a)	
Hf	44.7 (a)					2.29	11	6.67	(a)	
Ta	10.1 (a)					0.08	0.96	0.86	(a)	
W ppb										
Re ppb				0.046	0.059	(c)				
Os ppb				0.007		(c)				
Ir ppb				0.006	0.343	(c) <1	<3	<1	(a)	
Pt ppb										
Au ppb				0.051	0.25	(c) <1	<6		(a)	
Th ppm	39.4 (a)					0.53	39.4	4.73	(a)	
U ppm	11.1 (a)			11.5	4.1	(c) 0.07	1.6	1.25	(a)	

technique (a) INAA, (b) IDMS, (c) RNAA, (d) defocused beam analysis (electron probe)

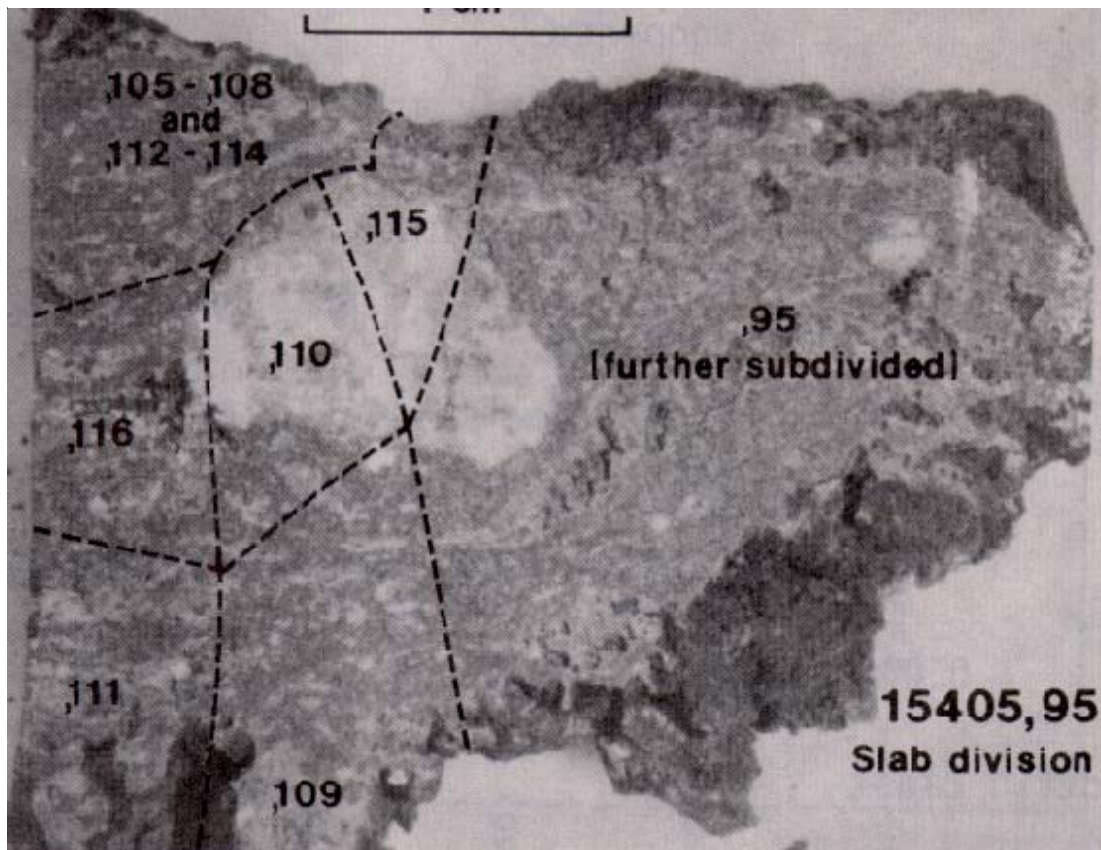

Figure 19: Processing diagram for half of slab (95) cut from 15405. The white clast is clast B of QMD lithology and is also exposed on 0 (figure 5)..

References for 15405

Bernatowicz T.J., Hohenberg C.M., Hudson B., Kennedy B.M. and Podosek F. (1978a) Argon ages for lunar breccias 14064 and 15405. *Proc. 9th Lunar Planet. Sci. Conf.* 905-919.

Butler P. (1971) Lunar Sample Catalog, Apollo 15. Curators' Office, MSC 03209

Christian R.P., Berman S., Dwornik E.J., Rose H.J. and Schnepfe M.M. (1976) Composition of some Apollo 14, 15 and 16 lunar breccias and two Apollo 15 fines (abs). *Lunar Sci. VII*, 138-140. Lunar Planetary Institute, Houston.

Drozd R.J., Kennedy B.M., Morgan C.J., Podosek F.A. and Taylor G.J. (1976) The excess fission Xenon problem in lunar samples. *Proc. 7th Lunar Sci. Conf.* 599-623.

Fleischer R.L. and Hart H.R. (1972) Particle track record of Apollo 15 green soil and rock. In **The Apollo 15 Lunar Samples**, 368-370.

Fleischer R.L. and Hart H.R. (1973) Particle track record of Apollo 15 green soil and rock. *Earth Planet. Sci. Lett.* **18**, 357-364.

Ganapathy R., Morgan J.W., Krahenbuhl U. and Anders E. (1973) Ancient meteoritic components in lunar highland rocks: Clues from trace elements in Apollo 15 and 16 samples. *Proc. 4th Lunar Sci. Conf.* 1239-1261.

Gros J., Takahashi H., Hertogen J., Morgan J.W. and Anders E. (1976) Composition of the projectiles that bombarded the lunar highlands. *Proc. 7th Lunar Sci. Conf.* 2403-2425.

Laul J.C. and Schmitt R.A. (1973b) Chemical composition of Apollo 15, 16, and 17 samples. *Proc. 4th Lunar Sci. Conf.* 1349-1367.

Lindstrom M.M., Marvin U.B., Vetter S.K. and Shervais J.W. (1988) Apennine front revisited: Diversity of Apollo 15 highland rock types. *Proc. 18th Lunar Planet. Sci. Conf.* 169-185. Lunar Planetary Institute, Houston.

LSPET (1972a) The Apollo 15 lunar samples: A preliminary description. *Science* **175**, 363-375.

LSPET (1972b) Preliminary examination of lunar samples. Apollo 15 Preliminary Science Report. NASA SP-289, 6-1—6-28.

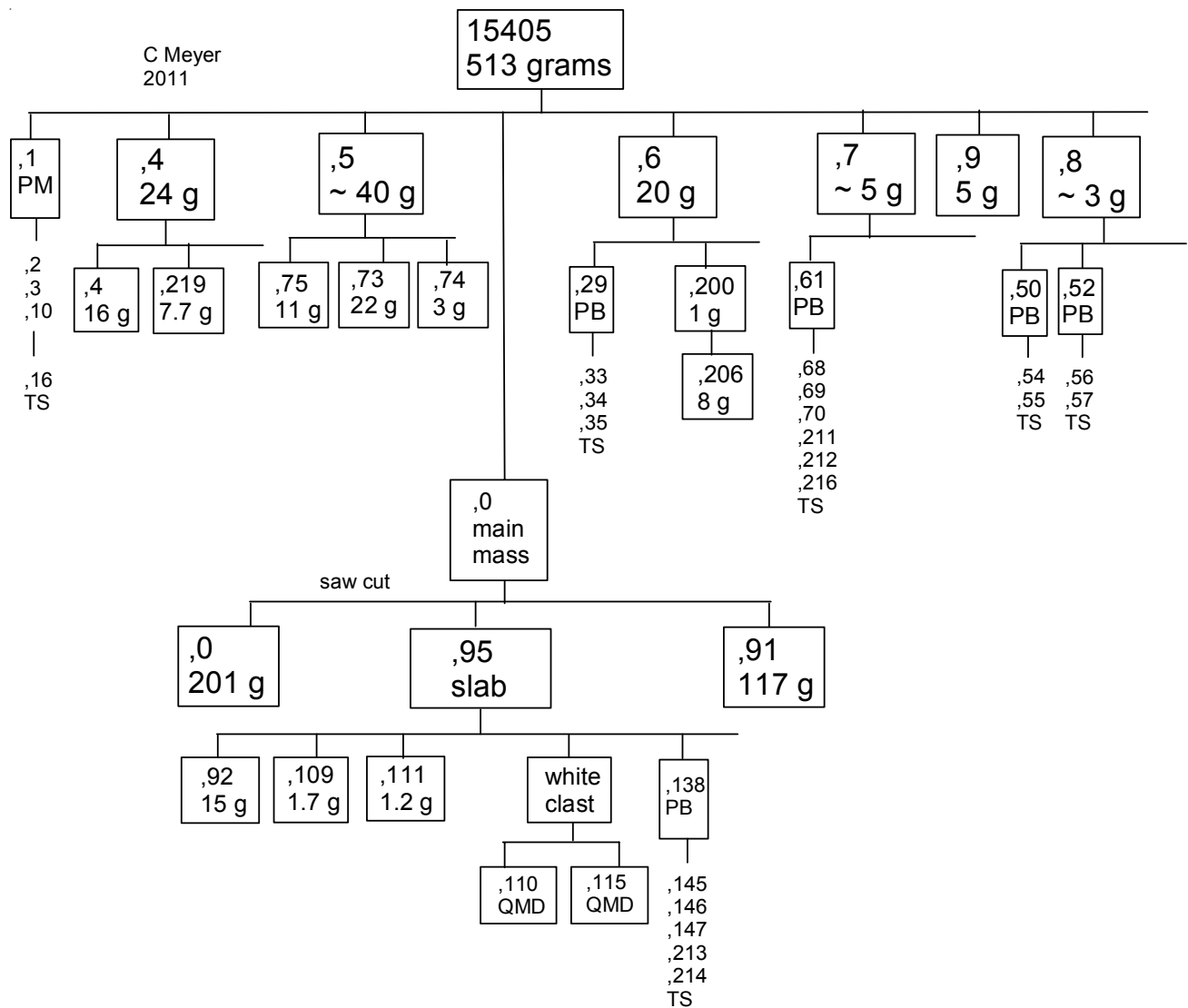

Marvin U.B., Hohenberg B.B. and Lindstrom M.M. (1990) New pieces of the lunar granite-quartz monzodiorite puzzle (abs). *Lunar Planet. Sci.* **XXI**, 738-739. Lunar Planetary Institute, Houston.

Marvin U.B., Lindstrom M.M., Holmberg B.B. and Martinez R.R. (1991) New observations of quartz monzodiorite-granite suite. *Proc. 21st Lunar Planet. Sci. Conf.* 119-136. Lunar Planetary Institute, Houston.

McGee P.E., Warner J.L., Simonds C.E. and Phinney W.C. (1979) Introduction to the Apollo collections. Part II: Lunar Breccias. Curator's Office. JSC

Meyer C., Williams I.S. and Compston W. (1996) Uranium-lead ages for lunar zircons: Evidence for a prolonged period of granophyre formation from 4.32 to 3.88 Ga. *Meteor. & Planet. Sci.* **31**, 370-387.

Nyquist L.E., Wiesmann H., Shih C-Y. and Bansal B.M. (1976c) 15405 quartz-monzodiorite: Super KREEP. In Wood and 27 others. Imbrium Consortium.

Podosek F.A. and Walker R.M. (1976) Rare gas and Fission Track Analysis. In Imbrium Consortium see Wood and 27 others.

Ryder G. (1976) Lunar sample 15405: Remnant of a KREEP basalt-granite differentiated pluton. *Earth Planet. Sci. Lett.* **29**, 255-268.

Ryder G. (1985) Catalog of Apollo 15 Rocks (three volumes). Curatorial Branch Pub. # 72, JSC#20787

Ryder and Bower (1975) Petrology. In Ryder and 27 others

Ryder G. and Norman M.D. (1979a) Catalog of pristine non-mare materials Part 1. Non-anorthosites, revised. NASA-JSC Curatorial Facility Publ. JSC 14565, Houston. 147 pp.

Ryder G. and Norman M.D. (1979b) Catalog of pristine non-mare materials Part 2. Anorthosites. Revised. Curators Office JSC #14603

Ryder G. and 27 authors (1976) Interdisciplinary studies by the Imbrium Consortium: Samples 14064, 14082, 14312, 14318, 15405, 15445 and 15455. 2 vol. Harvard U. (pink and green literature)

Swann G.A., Hait M.H., Schaber G.C., Freeman V.L., Ulrich G.E., Wolfe E.W., Reed V.S. and Sutton R.L. (1971b) Preliminary description of Apollo 15 sample environments. U.S.G.S. Interagency report: 36. pp219 with maps

Swann G.A., Bailey N.G., Batson R.M., Freeman V.L., Hait M.H., Head J.W., Holt H.E., Howard K.A., Irwin J.B., Larson K.B., Muehlberger W.R., Reed V.S., Rennilson J.J., Schaber G.G., Scott D.R., Silver L.T., Sutton R.L., Ulrich G.E., Wilshire H.G. and Wolfe E.W. (1972) 5. Preliminary Geologic Investigation of the Apollo 15 landing site. *In Apollo 15 Preliminary Science Rpt.* NASA SP-289. pages 5-1-112.

Takeda H., Mori H., Ishii T. and Miyamoto M. (1981) Thermal and impact histories of pyroxenes in lunar eucrite-like gabbros and eucrites. *Proc. 12th Lunar Planet. Sci. Conf.* 1297-1313.

Tatsumoto M. and Unruh D.M. (1976) KREEP basalt age: Grain by grain U-Th-Pb systematic study of the quartz monozodiorite clast 15405,88. *Proc. 7th Lunar Sci. Conf.* 2107-2129.

Taylor G.J., Warner R.D., Keil K., Ma M.-S. and Schmitt R.A. (1980) Silicate liquid immiscibility, evolved lunar rocks, and the formation of KREEP. *In Proc. Conf. Lunar Highlands Crust*, Geochim. Cosmochim. Acta Suppl. 12. Pergamon Press. 339-352. Lunar Planetary Institute, Houston.

Warren P.H. (1993) A concise compilation of petrologic information on possibly pristine nonmare Moon rocks. *Am. Mineral.* **78**, 360-376.

Wiesmann H. and Hubbard N.J. (1975) A compilation of the Lunar Sample Data Generated by the Gast, Nyquist and Hubbard Lunar Sample PI-Ships. Unpublished. JSC

Wood J.A. and a cast of 28 others (1977) Interdisciplinary studies by the Imbrium Consortium. Two volumes. Pink and Green literature.